



BS&B SAFETY SYSTEMS, INC.
BS&B SAFETY SYSTEMS LTD



GCR-N™ SANITARY REVERSE BUCKLING DISK

and NA-connect® disk holder



The GCR-N™ and GCR-NS™ reverse buckling disks may be quickly and simply installed in a NovAseptic NA-connect® holder permitting flush mounting of the disk with the interior wall of the vessel allowing easy cleaning and sterilization.

Innovative GCR-N™ design using SAF™ technology (Structural Apex Forming) offering a wide range of burst pressures for sanitary/aseptic applications in the pharmaceutical, biotechnology and food industries.

- One disk design for gas and liquid service
- Flush mounting with vessel wall
- Fail-safe design - Damage-Safety Ratio ≤ 1
- Low to high Burst Pressures
- Ideal for CIP/SIP Service*
- Installed with Integral Sanitary/Aseptic Gaskets
- 8 to 16 micro-inch typical disk surface finish
- Minimum dead space between process fluid and the disk
- Suitable for operating pressures up to 90% of Marked Burst Pressure** or 95% of the specified minimum burst pressure (CEN standard pending)
- Designed for non-fragmentation
- Standard Manufacturing Design Range, zero%, optional -5%, -10%
- Withstands full vacuum at all Burst Pressures
- SAS™ (Sanitary Alert Sensor) with leak sensing option available
- Integral burst disk sensor option
- Worldwide patents pending

*Clean/Steam in Place

**At marked burst pressures of 2.76 barg (40 psig) and below, the recommended maximum operating pressure is 90% of the marked burst pressure, less 0.138 barg (2 psig) tolerance.

GCR-N™ DISK SPECIFICATION MIN/MAX BURST PRESSURE AT 22°C (72°F) barg (psig)

Nominal Disk Size		Burst Pressure		Inlet Height (T)		NA-connect® holder type
mm	in	Minimum	Maximum	mm	in	
40	1.5	0.69	10 7 101	11	0.43	NAC - 38
50	2	0.69	10 7 101	11	0.43	NAC - 51

NA-connect® design pressure is 7 barg (101 psig) at 150°C (302°F)

Other Burst Pressures may be available, consult BS&B Safety Systems, Inc. or BS&B Safety Systems Ltd.

Design

The GCR-N™ family of reverse buckling disks is designed with a circular score line located at the edge of the domed area. At the marked burst pressure the disk's dome reverses and opens by shearing around the circular score line. The GCR-N™ offers very low burst pressures with excellent opening characteristics. An integral energy absorbing hinge located on the downstream side of the disk enables the disk to perform in gas or liquid service with superior flow performance. The hinge design interacts with the holder outlet bore to retain the disk on opening, avoiding fragmentation.

Manufacturing Design Range†

The standard Manufacturing Design Range for the GCR-N™ disk is 0%. The user's requested burst pressure will be the Marked Burst Pressure. Optional Manufacturing Design Ranges of -5% and -10% may be selected as operating conditions permit. The Manufacturing Design Range is applied to the minus side only of the requested burst pressure.

Example:

Requested Burst Pressure 3 barg (43.5 psig).

Agreed Manufacturing Design Range -10%.

Therefore the Marked Burst Pressure shall be between 2.7 barg (39 psig) and 3 barg (43.5 psig).

† Manufacturing Design Range is a range of pressures within which the marked burst pressure must fall to be acceptable for a particular requirement as agreed upon between the Rupture Disk Manufacturer and the user or his agent.

Burst Tolerance

Marked Burst Pressure	Burst Tolerance
≤ 2.76 barg (40 psig)	± 0.138 barg (2 psig)
> 2.76 barg (40 psig)	$\pm 5\%$

The GCR-N™ disks may be marked with a minimum-maximum burst pressure in which case the burst test values must be within the min-max burst range (as per CEN ISO 4126-2 standard pending). Add the Manufacturing Design Range and the Burst Tolerance to determine a min-max burst range.

Flow Performance

The GCR-N™ Sanitary Reverse Buckling Disk has been specifically developed to produce superior flow performance at all burst pressures in gas or liquid service. The circular score on the disk's dome, coupled with the non-restrictive hinge on the outlet side of the disk, ensures an excellent pressure relief opening.

Flow Resistance Factor K_R may be used to determine the relieving capacity of a system according to the CEN (pending) and ASME codes. Individual K_R values have been established for both gas and liquid service for the disk. Minimum Net Flow Area (MNFA) for each disk size is provided to assist with ASME sizing calculations. Net Relief Area has been provided for sizing according to European and International standards.

Gaskets

The GCR-N™ is supplied with FDA approved Silicone, Viton® (white or black) and EPDM (white or black) gaskets ensuring correct and leak-tight installation in type NA-connect® disk holders.

GASKET SERVICE TEMPERATURE

Material	MINIMUM Service Temperature	MAXIMUM Service Temperature
Silicone	-55°C (-67°F)	232°C (450°F)
Viton®	-40°C (-40°F)	204°C (400°F)
EPDM	-55°C (-67°F)	149°C (300°F)

Materials

The disk is available in 316SS and 316LSS as standard. NAC holder materials, welding flange 316L/W1.4335, locking ring 316L/W1.4404. Alternative materials are available on request.

Liners

Liners are available in all sizes as optional on the process side of the disk. FEP or PFA are generally used.

Temperature Range FEP -40°C to 204°C (-40°F to 400°F)
PFA -40°C to 260°C (-40°F to 500°F)

Size		Minimum Burst Pressure for lined disks at 22°C (72°F)	
mm	in	psig	barg
40	1.5	36	2.48
50	2	36	2.48

SAF™ technology: Damage-Safety Ratio ≤ 1

Structural Apex Forming, the precision indentation present in all GCR-N™ Rupture Disks, combined with the unique energy absorbing hinge design ensures that a damaged disk will rupture at or below the marked burst pressure.

K_R values MINIMUM NET FLOW AREA (MNFA), Net Relief Area (NRA) values

Disk Size	1½" 40mm	2" 50mm
K_{RG}	1.95	1.25
*MNFA in²	1.50	2.70
**NRA cm²	9.67	17.40

K_R values applicable with or without integral burst sensors

* Use MNFA in² when sizing according to ASME Code, para UG-127(a)(2)(a)

**Use NRA cm² (Net Relief/Area) when sizing according to European standards

The K_R values indicated are for gas service. The GCR-N™ disks have been performance tested for both gas and liquid service, contact BS&B Safety Systems, Inc or BS&B Safety Systems Ltd for liquid service K_R values. CE marking of bursting disks is available.

Sensors

The GCR-N™ disk is also available with an integral sensor to provide warning of a burst rupture disk, specify type GCR-NS™.

Installation

The GCR-N™ (or GCR-NS™) sanitary reverse buckling disk ensures leak tight installation in a NA-connect™ holder. The GCR-N™ disk range, using SAF™ technology, exhibits minimum sensitivity to changes in clamp loading on the disk induced by service temperature variations. However an adequate clamping load to maintain leak tightness must be maintained.

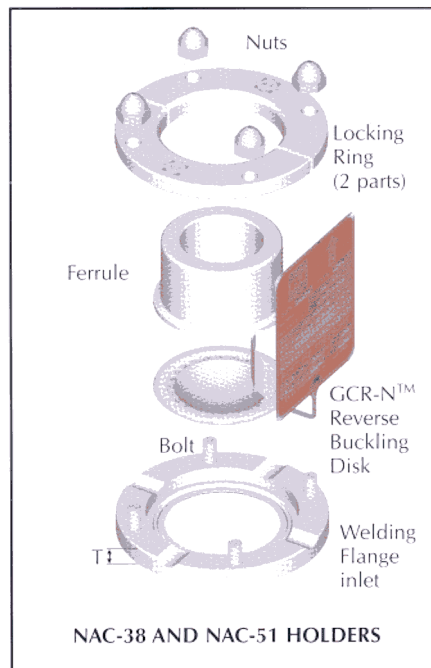

ALTERNATIVE SANITARY DISKS AND HOLDERS

Disk Type	Holders (See Cat 77-4014)
GCR-S™	GR-C™
GCR-SM™	Standard ferrules
GCR-SE™	FM-C™, FT-C™
GCR-SW™	Welded ferrule assembly

The FM-C™ holder offers an alternative flush mounting disk installation. The FT-C™ holder offers an inline normal flow path with a side 'T' housing the disk.

Products, specifications and all data in this literature are subject to change without notice. Questions regarding product selection and specifications for specific applications should be directed to BS&B Safety Systems, Inc. or BS&B Safety Systems Ltd.

All sales are subject to BS&B Safety Systems, Inc. or BS&B Safety Systems Ltd. standard terms and conditions of sale.

Viton® is a trademark of DuPont Dow Elastomers LLC.

NA-connect® is a registered trademark of NovAseptic Equipment AB

US Patents 5,050,630 - 5,996,605 - 6,178,983 and other patents pending



BS&B SAFETY SYSTEMS, INC
BS&B SAFETY SYSTEMS LTD

BS&B SAFETY SYSTEMS LTD.

Raheen Business Park,
Limerick, Ireland
Tel: +353 61 227022
Fax: +353 61 227987
E-mail: sales@bsb.ie
www.bsb.ie

BS&B SAFETY SYSTEMS (UK) LTD

Adamson House, Towers Business Park,
Wilmslow Road, Manchester
M20 2YY England
Tel: +44 161-955 4202
Fax: +44 161-955 4282
E-mail: sales@bsb-systems.co.uk
www.bsb.ie

BS&B SAFETY SYSTEMS, INC.

7455 East 46th Street, Tulsa,
OK 74145, USA
Tel: +1 918 622-5950
Fax: +1 918 665-3904
E-mail: sales@tul.bsb-systems.com
www.bsb-systems.com